



扫一扫敬请关注  
林肯电梯微信公众号



扫一扫观看  
林肯别墅电梯介绍视频

林肯别墅电梯介绍视频请关注LINCOLN官方微信

林肯电梯(中国)有限公司  
Lincoln Elevator (China) Co., Ltd.  
2018年4月印刷 Printed in April 2018

专业铸就品质, 服务体现价值  
Profession Cast The Quality, Service Reflect The Value



全国服务热线 400-826-9599  
National Service Hotline

林肯电梯(中国)有限公司  
Lincoln Elevator(China) Co., Ltd.

地址: 中国浙江省海宁市尖山新区凤凰路78号  
Add: No.78 Fenghuang Road Jianshan New District Haining Zhejiang China  
电话(Tel): +86-573-87805995 传真(Fax): +86-573-87805996  
E-mail: sales@lincolnelevator.com.cn  
网址(Web): www.lincolnelevator.com.cn

*Safe and intelligent*

安全 智能 别墅电梯

Villa Elevator Series 别墅电梯系列

**LINCOLN**®

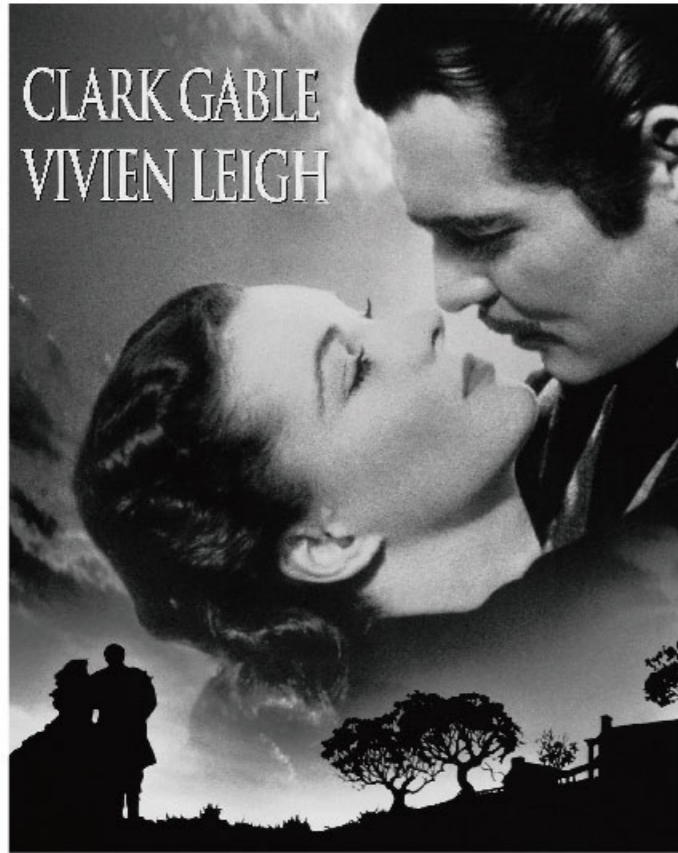

LINCOLN ELEVATOR  
since 1998

美国经典 林肯电梯  
秉承美国林肯总统的价值观：  
为荣誉而活

American classic, LINCOLN elevator  
Adhering to value of American president LINCOLN:  
Live for honor.

A glorious choice for  
modern spaces, unique dignity



*A glorious choice  
for modern spaces,  
unique dignity*

现代空间的美好之选, 尊贵不可复制

潜心钻研, 十余年造就尊贵不凡  
卓越科技, 由美国不远千里而来  
从郝思嘉的罗塔庄园, 到温馨的家庭空间  
我们都有对幸福的独特追求  
林肯别墅电梯, 匠心设计, 荣耀非凡  
细心守护您的家园

Ten years of research creates noble and dignity  
Adopt excellent technology from remote United States  
From Scarlett O'hara' s Rota Plantation to the sweet family space  
We are always in pursuit for distinctive happiness  
LINCOLN villa elevator, with distinctive design  
Carefully defends your homeland

# Safety Eco-system

安全生态系统

云服务, 新生态

Cloud services, new ecological



## 安全生态系统 Safety Eco-system

机械电气连锁  
部件寿命预警  
后备电源支持  
柔性钢带拖动

Mechanical and electrical Interlock  
Components' service life warning  
Back-up source support  
Dragging by flexible steel belt

## 智慧物联工程 Intelligent IOT project

私密手机对话  
智能家居接入  
数据云端修复  
人脸自动识别

Private phone call  
Smart home access  
Data cloud recovery  
Automatic identification of faces

## 优雅生活体验 Elegant life experience

主机静音设计  
液晶人机界面  
多彩轿厢风格  
健康保健魔盒

Sound-free design of main machine  
LCD human-computer Interface  
Colorful cabin style  
Health care magic box

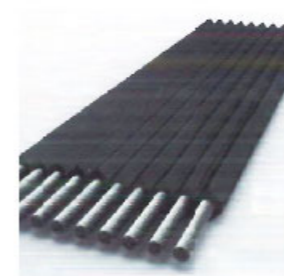

### 柔性钢带拖动

采用扁平复合钢带设计, 提高了曳引摩擦力。钢带的聚氨酯包层有效减少了摩擦损耗, 无需额外润滑, 比传统钢丝绳更节能环保、牢固耐用。

### Dragging by flexible steel belt

Apply flat and compound steel belt design, which highly creases traction friction. Polyurethane cladding for steel belt effectively reduces frictional loss and it needn't extra lubrication. Therefore, it is more energy-saving, environmental, firm and durable than traditional steel rope.

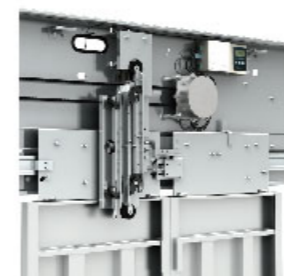

### 机械电气连锁

电梯电气系统发出精确指令, 相应机械装置对指令迅速作出反应, 双向联动, 安全无忧。

### Mechanical and electrical interlock

Electrical system sends precise command and correspond mechanical device will response to the command quickly. Bi-directional interlock enhances elevator safety.



### 部件寿命预警

每部电梯配备了完善的自检测装置, 能对电梯速度, 开关门状态, 曳引机温度和抱闸力, 接触器等进行检测, 这些装置能将检测到的数据反馈给数据云服务平台, 在部件可能发生故障前预警, 避免事故发生。

### Components' service life warning

Each elevator is equipped with a complete self-checking device that can detect elevator speed, door open/close status, traction machine temperature and brake force, contactors and so on. These devices can send the detected data back to the data cloud service platform, which can give early warning before possible failure of components to avoid accidents.



### 后备电源支持

双电源设计, 当供电系统发生故障, 常用电源停用时, 后备电源会自动启动, 使电梯仍能正常运行, 保障了乘梯人的安全和便利。

### Back-up source support

Apply dual power supply design. In case of power failure, back-up source will work automatically to enable elevator work normally, which guarantees safety and convenience for passengers.

### 私密手机对话

电梯拥有良好的隔音功能,乘梯人在电梯中接听电话时,不必担心会被电梯外的人听到,充分保障了隐私与安全。

### Private phone call

When passenger answers call in elevator, there is no need to worry to be heard because of excellent sound insulation function. It assures privacy and security for passengers.

### 数据云端修复

所有故障信息自动上传至数据云平台,对于小范围的数据错误可实现自动修复;较严重的问题会自动报警,通知维保或物业人员,并给出维修建议。

### Data cloud recovery

All failure information will be sent to data cloud platform automatically. Data errors of small scope can be recovered automatically. For serious problem, it will alarm automatically to inform the maintenance or property management staff and give maintenance suggestions.

### 智能家居接入

可以一键远程开关家用电器。天热了,可以提前打开空调;出门匆忙忘记关灯,可以在电梯中点击关闭.....更智能的乘梯感受,让生活更加便利。

### Smart home access

Apply one-touch remote control. You can turn on air conditioning in advance if it is hot; you can turn off lights in elevator if forgotten. Smarter ride experience, makes life more convenient.

### 自动识别呼梯

电梯设有人脸识别、指纹识别、二维码呼梯、手机呼梯等多种呼梯模式,能迅速确定呼梯人的身份,高度防伪、简便易用、准确安全。

### Automatic identification of calling

Elevator has several calling modes, such as face identification, fingerprint recognition, QR code calling and phone calling, which can quickly identify calling passengers. It is high-security simple, convenient, accurate and safe.



# IOT project

智慧物联网, 24小时保障安全  
Intelligent IOT project, 24-hour safety & security

智慧物联工程  
让电梯聪明起来

Make the  
elevator become  
intelligent

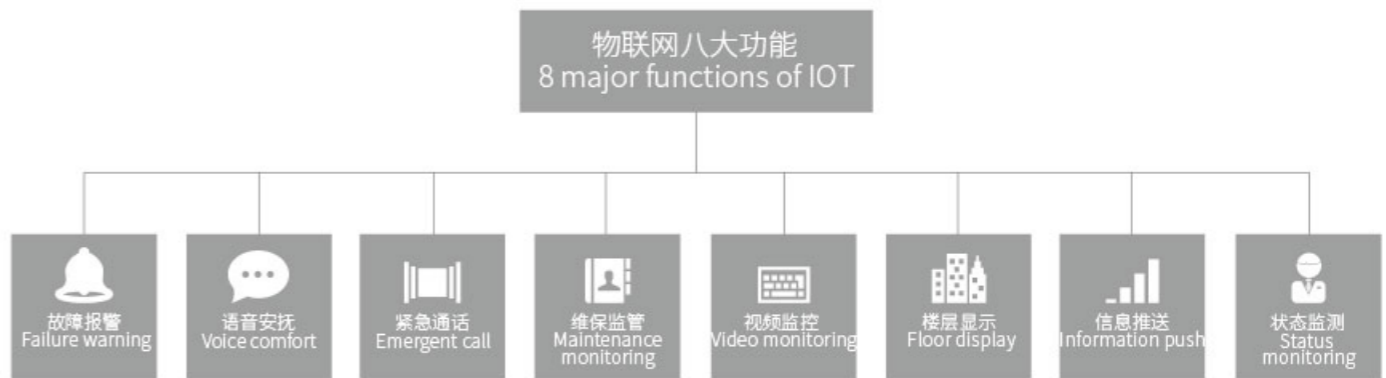



### 多彩轿厢风格

轿厢风格多样,可根据用户需求自由选择,遵循现代美学风格,装潢尊贵大气,以精湛工艺与建筑完美结合,品质超乎想象。

### Colorful cabin style

Lincoln provides various styles for cabin decoration for user's selection. It follows modern aesthetic style and decoration is honorable and noble. It is a perfect combination of exquisite craft and building, with top quality.

### 智能保健魔盒

高效防霉过滤网,清除灰尘;优质冷触媒,去除有害气体;负氧离子杀菌,净化轿厢内空气,彻底杀灭多种病菌(选配功能);紫外线强力杀菌系统,快速彻底杀灭多种病菌(选配功能)。

### Health care magic box

High efficient mould proof filtration mesh can remove dust; High quality cold catalyst can remove harmful gas; Negative oxygen ion can sterilize and purify the air in the cabin (optional functions); UV sterilization system will also kill several types of germs thoroughly (optional functions).

*Elegant Life  
experience*

### 主机静音设计

家用专用主机设计,常规电压,超小功率,超低能耗,无噪音污染,让您在宁静之中不知不觉到达目的层。

### Sound-free design of main machine

Apply specialized machine design, with features like normal voltage, small power and low energy consumption and no noise. It takes you to target floor smoothly.

### 液晶人机界面

配备全球领先的液晶界面,具备灵活的人机功能,可提供天气预报、体重指数计算、小区物业公告等数据信息,让乘客在乘坐过程中实时获取资讯,感受全新的乘梯体验。

### LCD human-computer interface

The elevator is equipped with world-leading LCD interface with flexible functions. It can provide weather forecast, BMI calculation, announcement of community and other information. Thus passengers can get information in elevator and enjoy new ride experience.

Focus on design  
Enjoy perfect life

优雅生活体验

专注设计 静享家之极致

# Car Decoration

轿厢装潢设计  
(标配)

A glorious choice for modern spaces,  
unique dignity

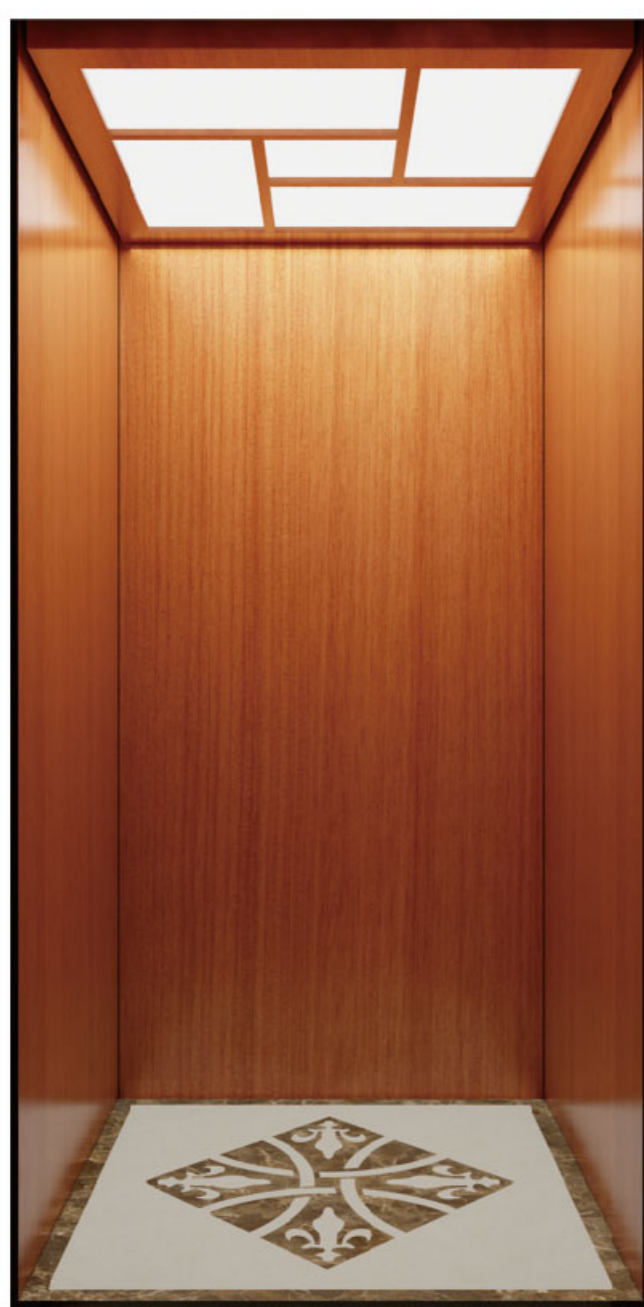

扫描二维码360度了解轿厢  
Scan the QR code to know  
more about the car in the  
360-degree manner



**LCV-01**  
标准配置 Standard configuration

吊顶: 木纹贴塑钢板框架, 亚克力  
轿壁: 木纹贴塑钢板  
地板: PVC地板  
Ceiling: Plastic coated steel plate with wooden grain frame, acrylic  
Car wall: Plastic coated steel plate with wooden grain  
Floor: PVC floor

**LCV-07**  
标准配置 Standard configuration

吊顶: 镜面不锈钢框架, 亚克力  
轿壁: 发纹不锈钢  
扶手: 不锈钢圆管  
地板: 米黄色PVC地板  
Ceiling: Mirror stainless steel frame, acrylic  
Car wall: Hairline stainless steel  
Handrail: Stainless steel pipe  
Floor: Beige PVC floor

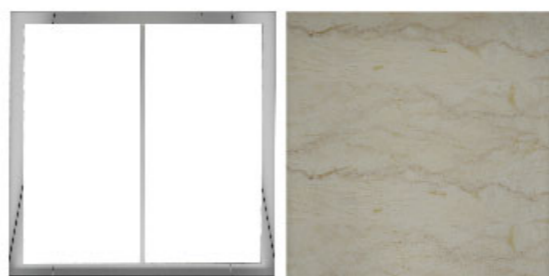

扫描二维码360度了解轿厢  
Scan the QR code to know  
more about the car in the  
360-degree manner



林肯为您提供多种组合任您挑选  
Lincoln offers various combinations for your kindly selection  
请注意, 图像和颜色可能与实际情况稍有差异, 材料可在事先告知的情况下有所改变。  
Note: Picture and color may vary from actual material. Material can be altered with advance notice.

轿厢装潢设计  
(选配)

# Car Decoration

A glorious choice for modern spaces,  
unique dignity

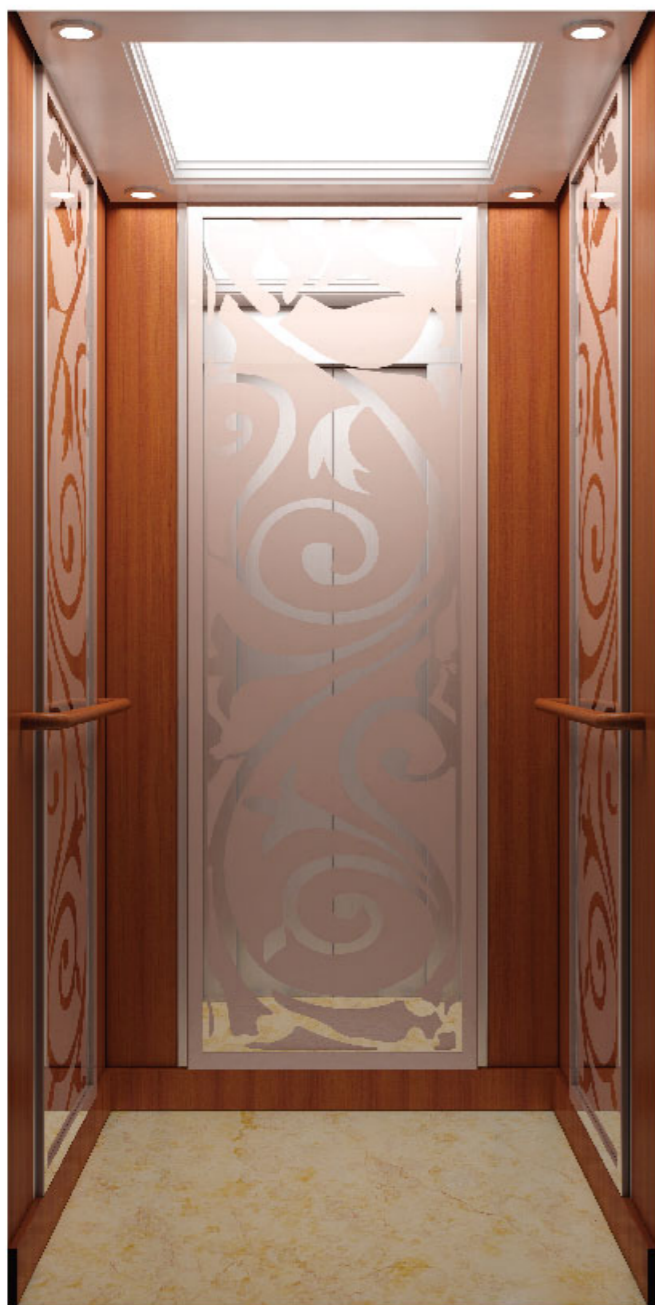

## LCV-08

选择配置 Optional configuration

吊顶: 木质框架, LED回光灯带+LED筒灯  
轿壁: 木饰面, 发纹不锈钢, 艺术玻璃  
扶手: 实木和不锈钢圆管组合  
地板: PVC地板

Ceiling: Wooden frame, LED strip+ LED tube light  
Car wall: Wood veneer, hairline stainless steel, glass  
Handrail: Solid wood and stainless steel pipe  
Floor: PVC floor

## LCV-09

选择配置 Optional configuration

吊顶: 木质框架, LED回光灯带+LED筒灯  
轿壁: 木饰面, 雾面不锈钢镀香槟金  
扶手: 不锈钢圆管镀钛  
地板: PVC地板

Ceiling: Wooden frame, LED strip + LED tube light  
Car wall: Wooden veneer, matt polished champagne gold clad stainless steel  
Handrail: Stainless steel pipe coated with titanium  
Floor: PVC floor

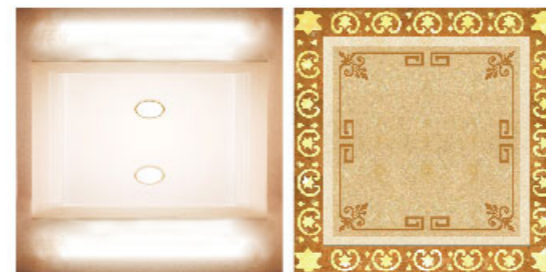

林肯为您提供多种组合任您挑选

Lincoln offers various combinations for your kindly selection

请注意, 图像和颜色可能与实际情况稍有差异, 材料可在事先告知的情况下有所改变。

Note: Picture and color may vary from actual material. Material can be altered with advance notice.

# Car Decoration

轿厢装潢设计  
(选配)

A glorious choice for modern spaces,  
unique dignity



## LCV-10

选择配置 Optional configuration

吊顶: 发纹不锈钢, LED筒灯  
轿壁: 镜面不锈钢蚀刻, 皮纹贴塑钢板  
地板: PVC地板

Ceiling: Hairline stainless steel, LED tube light  
Car wall: Mirror etched stainless steel, leather plastic coated steel plate  
Floor: PVC floor

## LCV-11

选择配置 Optional configuration

吊顶: 木质框架贴金膜, LED回光灯带+LED筒灯  
轿壁: 实木线条, 钛金镜面不锈钢, 金属马赛克  
地板: 大理石拼花地板

Ceiling: Wooden frame with gold film, LED strip+ LED tube light  
Car wall: Solid wood line, titanium mirror stainless steel, metal mosaics  
Floor: Marble parquet floor

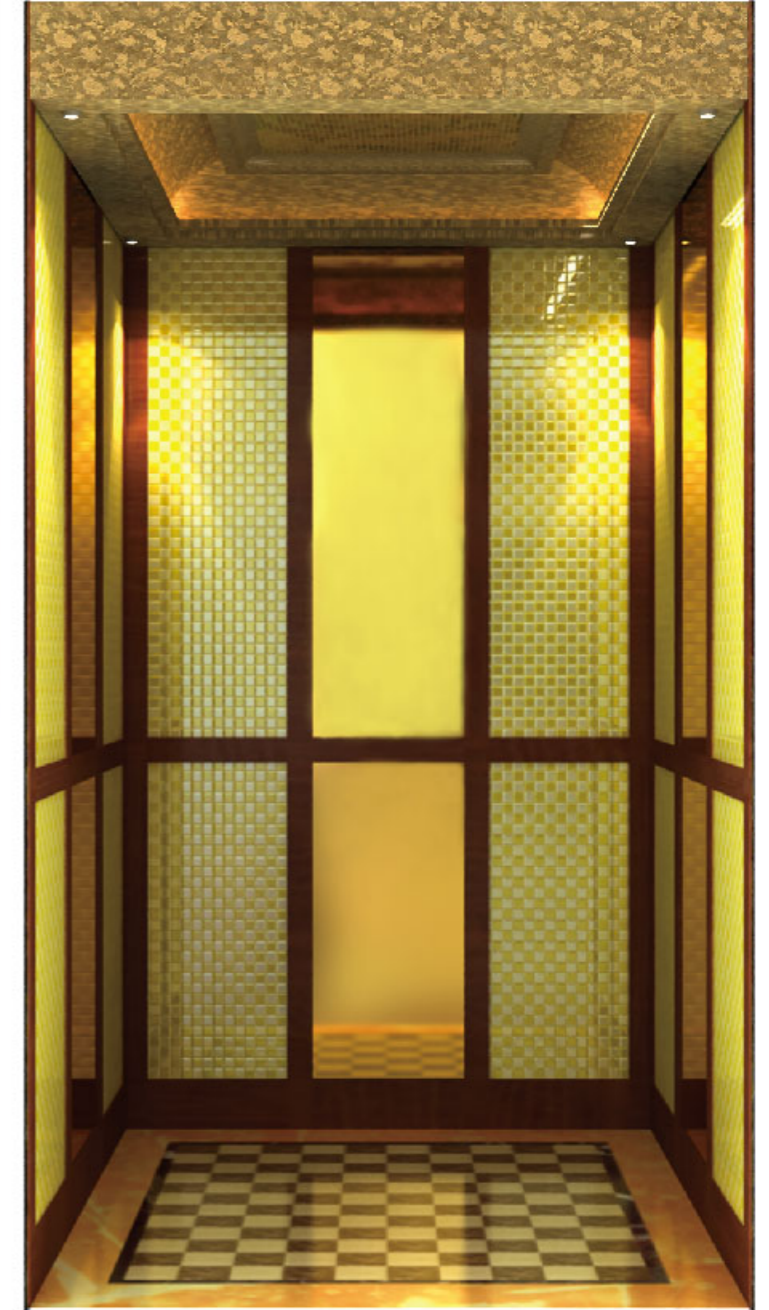
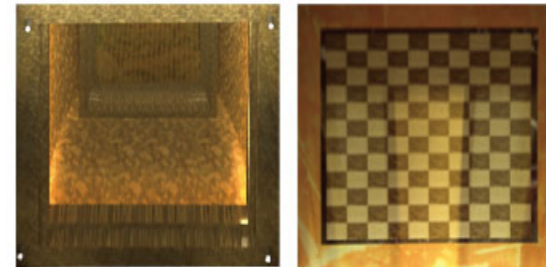

林肯为您提供多种组合任您挑选  
Lincoln offers various combinations for your kindly selection  
请注意, 图像和颜色可能与实际情况稍有差异, 材料可在事先告知的情况下有所改变。  
Note: Picture and color may vary from actual material. Material can be altered with advance notice.



系列装潢设计  
(选配)

# Series of decoration

Various styles of different designs reflect eternal aristocracy

人机界面  
Man-machine interface

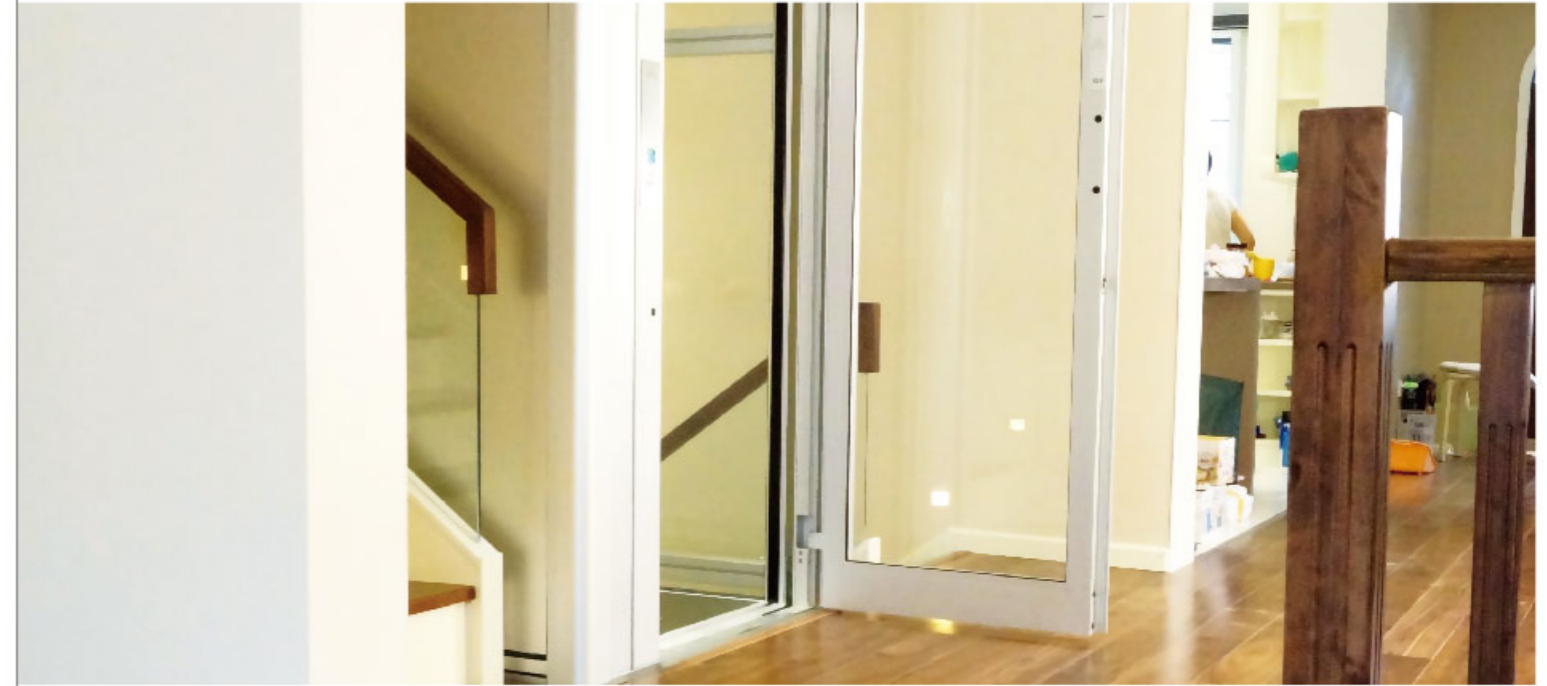

玻璃装饰 (夹丝玻璃)  
Glass decoration (wired glass)

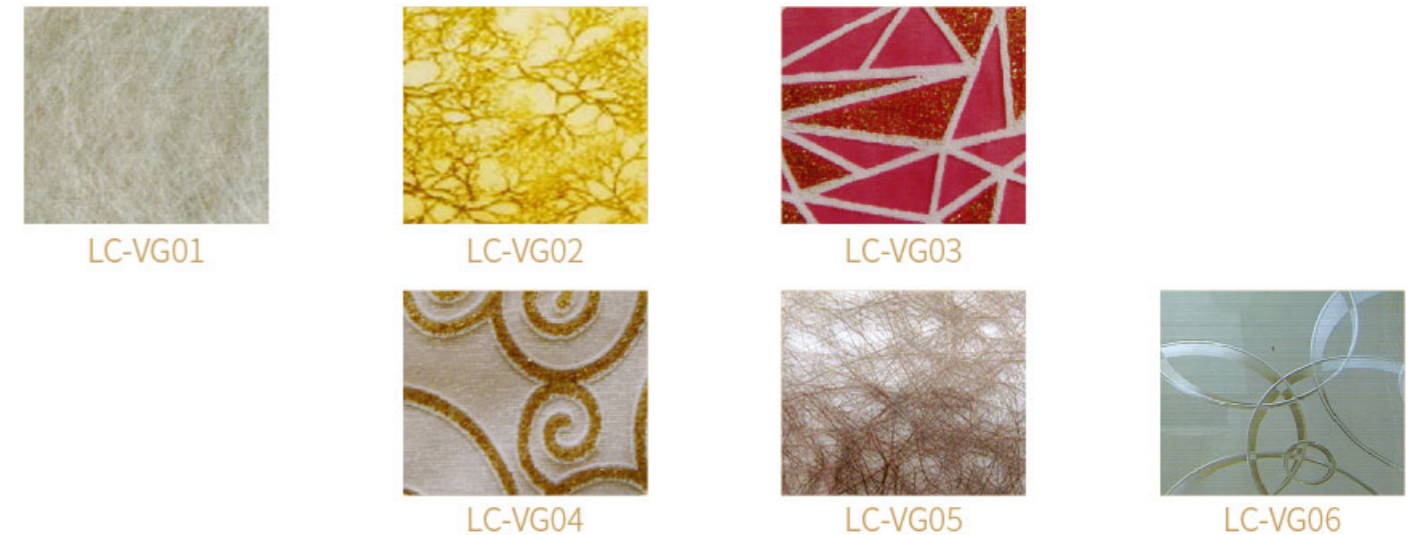

林肯为您提供多种组合任您挑选  
Lincoln offers various combinations for your kindly selection  
请注意, 图像和颜色可能与实际情况稍有差异, 材料可在事先告知的情况下有所改变。  
Note: Picture and color may vary from actual material. Material can be altered with advance notice.

系列装潢设计

# Series of decoration

Various styles of different designs reflect eternal aristocracy

## 吊顶 Ceiling

标配 Standard



**LC-VT-01**  
镜面不锈钢, 亚克力灯饰  
Mirror stainless steel, acrylic lighting

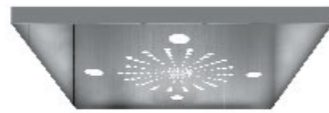

**LC-VT-02**  
镜面不锈钢, 亚克力灯饰, 筒灯  
Mirror stainless steel, acrylic lighting, tube lamp



**LC-VT-03**  
镜面不锈钢, 亚克力灯饰, 筒灯  
Mirror stainless steel, acrylic lighting, tube lamp



**LC-VT-04**  
镜面不锈钢, 亚克力灯饰, 筒灯  
Mirror stainless steel, acrylic lighting, tube lamp



**LC-VT-05**  
木纹贴塑钢板框架, 亚克力  
Plastic coated steel plate with wooden grain frame, acrylic



**LC-VT-06**  
镜面不锈钢框架, 亚克力  
Mirror stainless steel frame, acrylic

选配 Optional



**LC-VT-07**  
木质框架, LED回光灯带+LED筒灯  
Wooden frame, LED strip + LED tube light



**LC-VT-08**  
木质框架, LED回光灯带+LED筒灯  
Wooden frame, LED strip + LED tube light



**LC-VT-09**  
发纹不锈钢, LED筒灯  
Hairline stainless steel, LED tube light



**LC-VT-10**  
木质框架贴金膜, LED回光灯带+LED筒灯  
Wooden frame gold film, LED strip + LED tube light

## 扶手 Handrail



**LC-VF-03**  
实木和钛金不锈钢  
Solid wood and titanium stainless steel



**LC-VF-07**  
发纹不锈钢  
Hairline stainless steel



**LC-VF-09**  
发纹不锈钢  
Hairline stainless steel



**LC-VF-11**  
实木和钛金不锈钢  
Solid wood and titanium stainless steel



**LC-VF-13**  
亚克力和钛金不锈钢  
Acrylic and titanium stainless steel



**LC-VF-14**  
发纹不锈钢镀黄钛金  
Hairline stainless steel plated yellow titanium gold



## PVC地板 PVC floor

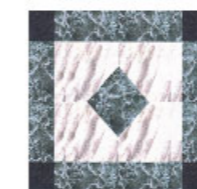

**LC-VN-01**



**LC-VN-02**

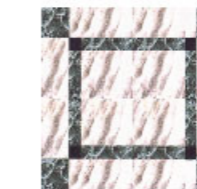

**LC-VN-03**

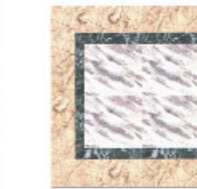

**LC-VN-04**

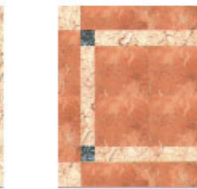

**LC-VN-05**



**LC-VN-06**

## 轿厢木纹贴塑钢板材质 Car plastic coated steel plate with wooden grain



**LC-VM-01**



**LC-VM-02**



**LC-VM-03**

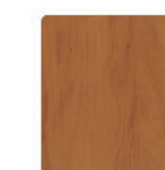

**LC-VM-04**

林肯为您提供多种组合任您挑选  
Lincoln offers various combinations for your kindly selection  
请注意, 图像和颜色可能与实际情况稍有差异, 材料可在事先告知的情况下有所改变。  
Note: Picture and color may vary from actual material. Material can be altered with advance notice.

Various styles of different designs reflect eternal aristocracy

手拉门门套  
hand sliding door & door pocket



LC-VMT-01  
手拉门: 浅米色  
Hand Door: Light beige

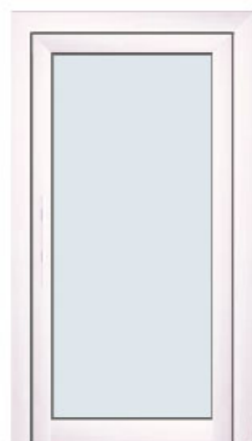

LC-VMT-02  
手拉门: 乳白色  
Hand Door: Cream white



LC-VMT-04  
手拉门: 棕色  
Hand Door: Brown



LC-VMT-05  
手拉门: 红棕色  
Hand Door: Reddish brown

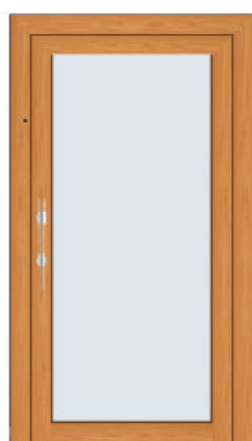

LC-VMT-06  
手拉门: 米色  
Hand Door: Beige

玻璃门  
Glass door



LC-VBL-01

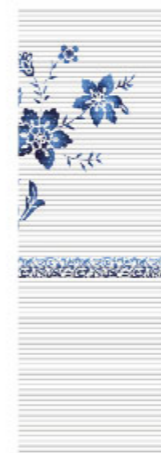

LC-VBL-02



LC-VBL-03



LC-VBL-04



LC-VBL-05



林肯为您提供多种组合任您挑选  
Lincoln offers various combinations for your kindly selection  
请注意, 图像和颜色可能与实际情况稍有差异, 材料可在事先告知的情况下有所改变。  
Note: Picture and color may vary from actual material. Material can be altered with advance notice.

系列装潢设计

# Series of decoration

Various styles of different designs reflect eternal aristocracy



LC-VS-07  
发纹不锈钢有框玻璃  
Hairline stainless steel framed glass



LC-VS-08  
玫瑰金镜面和纹蚀刻  
Rose gold mirror and grain etching



LC-VS-09  
钛金镜面拉丝蚀刻  
Titanium mirror drawing etching

不锈钢蚀刻门  
Stainless steel etched door



LC-VS-01  
发纹不锈钢  
Hairline stainless steel



LC-VS-02  
镜面蚀刻  
Mirror etched



LC-VS-03  
镜面蚀刻  
Mirror etched



LC-VS-04  
镜面不锈钢拉丝蚀刻喷金  
Mirror stainless steel wiredrawing etching metal spraying



LC-VS-05  
镜面蚀刻  
Mirror etched



LC-VS-06  
镜面拉丝蚀刻  
Mirror drawing etching



林肯为您提供多种组合任意挑选  
Lincoln offers various combinations for your kindly selection  
请注意, 图像和颜色可能与实际情况稍有差异, 材料可在事先告知的情况下有所改变。  
Note: Picture and color may vary from actual material. Material can be altered with advance notice.

# Steel wire rope driving (Side CWT)

别墅电梯土建  
钢丝绳牵引对重侧置系列

井道立面图  
Shaft Vertical Section

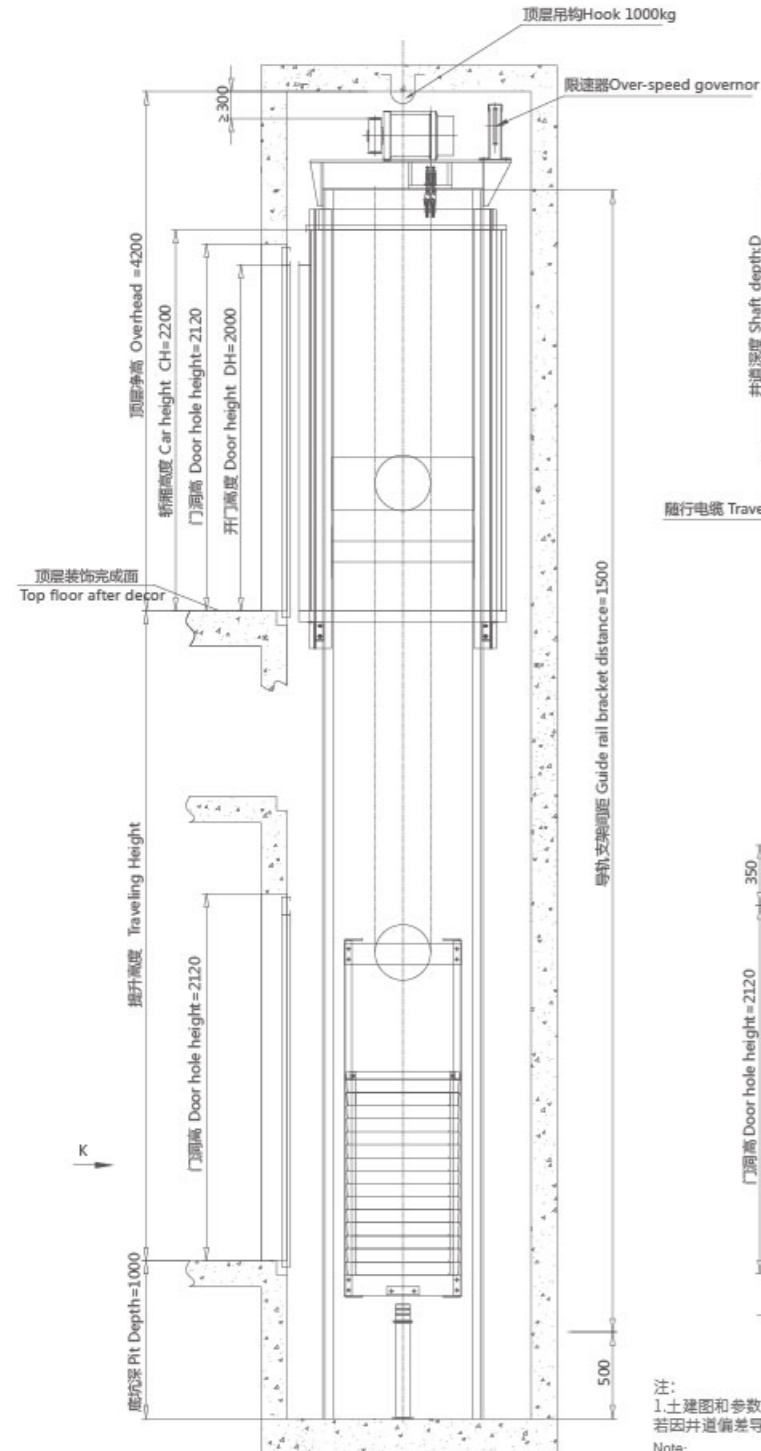

电梯平面布置图方案图  
Elevator plan

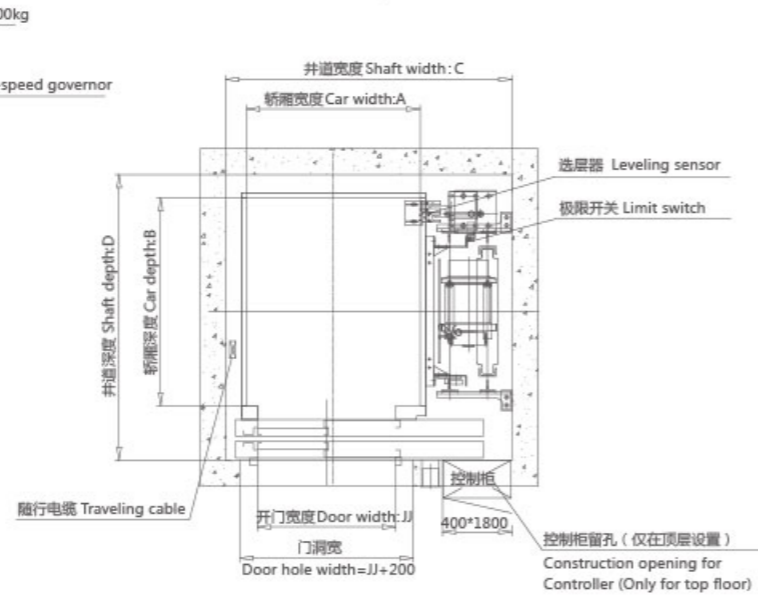

厅门正面图  
Landing door plan

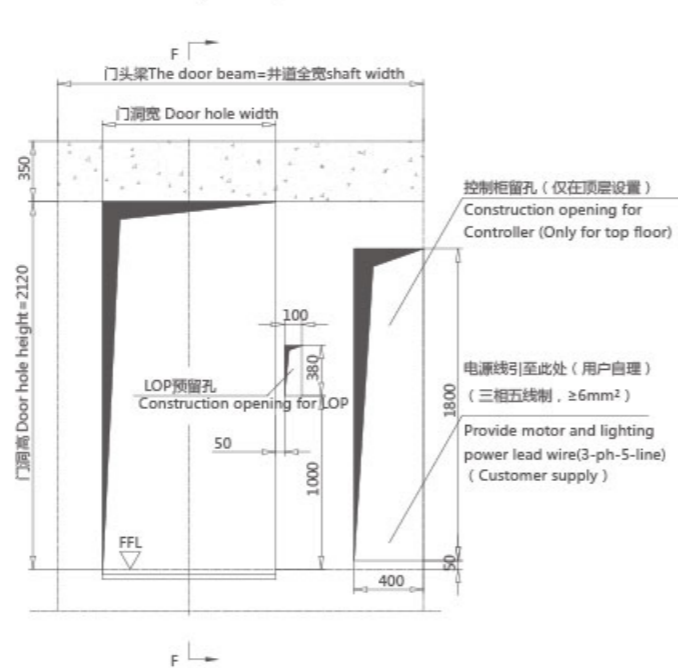

注:  
1. 土建图和参数表仅供销售参考, 如有疑问, 请咨询技术部。2. 请确保井道垂直度, 让电梯顺利安装, 若因井道偏差导致电梯无法安装的, 需用户自行解决!  
Note:  
1. Construction parameter drawings and tables are for sales reference only. Please consult the company's technical department if you have any question.  
2. Please make sure the shaft is vertical so that the elevator can be installed smoothly. If elevator can't be installed because of shaft deviation, user shall settle it by himself.

I 放大  
I Large icons

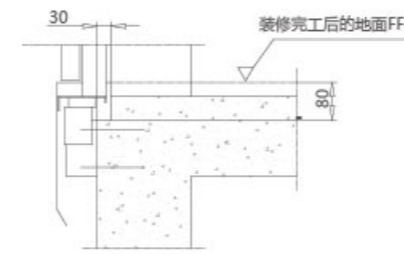

剖面  
Section F-F

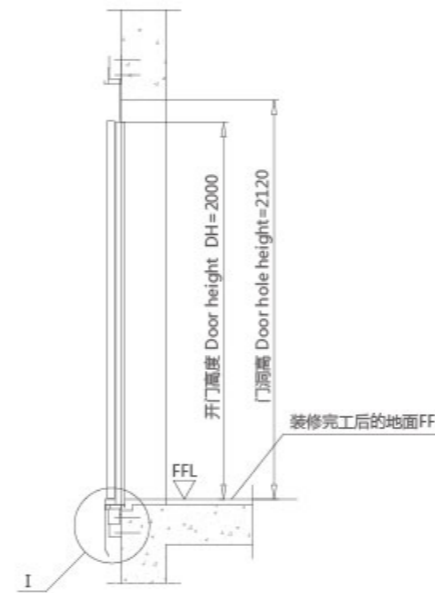

## 业主和土建承包商须注意事项 User and construction contractor should finish the following work

井道应为电梯专用, 不得装设与电梯无关的设备、电缆等。井道内允许装设采暖设备, 但不能用蒸汽和高压水加热, 采暖设备的控制与调节装置应装在井道外面。

电源需有适配的线, 电压220V, 电压波动应在±7%范围内, 其独立的接地装置, 其电阻不得大于4Ω。

井道净尺寸是用铅垂线测定的最小净空间尺寸, 井道高度允许偏差值为0到+25mm。砖混结构井道要求在导轨支架安装处设置300mm高的混凝土圈梁并在每层厅门洞设与井道同宽的混凝土梁, 见厅门正面图。

底坑地面应能够承受不小于规定的负荷; 底坑表面应光滑平整且不得漏水。

机械设备区间工作环境允许温度0°C到+40°C, 相对湿度不大于85%。

控制柜前至少提供宽度不小于0.7m, 深度不小于0.5m的工作区域。通往控制柜的通道应通畅, 且宽度不小于0.8m, 高度不小于1.8m。

最小层楼间距为2600mm, 当相邻层楼间距大于11m时, 应设置井道安全门, 安全门的尺寸不小于350mm宽、1800mm高, 不得向井道内开启。

控制柜旁应能设置电源箱, 电源箱应为电梯专用, 电源箱的位置须合适, 应易于专业人员操作。当电源箱处于公共用途的场地时, 应有防止非专业人员误操作的设置。零线和接地线应始终分开, 接地电阻不大于4Ω。

机器设备区内应设置永久照明, 地面的照度不小于200lx; 当机器设备区处于公共用途的场地时, 允许利用公共照明采光。

选手动门时请与本公司技术部联系。

The shaft is specialized for elevator. Do not install other irrelevant equipments and power. It is allowed to install heating equipment in shaft, but steam and high pressure water heating is forbidden. Controller and adjust device for heating equipment should be installed outside shaft.

The fluctuation of the power supply voltage with respect to voltage (220V) should be within the range of ±7%. For independent grounding device, its resistance value should be no more than 4Ω.

Shaft size is minimal net size measured by plumb line and vertical deviation 0~+25mm. If shaft is frame structure, install concrete ring beam (height: 300mm) at guide rail bracket install position and concrete beam (width: same as shaft width) at each landing door reserved holes. Please refer to landing door plan.

Strength of shaft wall and pit should bear the force no less than required value. Pit surface should be smooth, flat and with out leaking.

Temperature in equipment range should remain 0-40 deg, relative humidity ≤ 85%.

In front of controller, there should be a work area (width ≥ 0.7m, depth ≥ 0.5m). Passage to controller should be unobstructed, with width no less than 0.8m, and height no less than 1.8m.

The Minimum floor sill distance is 2600mm. If distance between two floor is more than 11 m, there should be a safety door. Door size should be no less than 350mm × 1800mm. Door can't come into shaft.

Install power box beside control cabinet and power box should be specialized for elevator. Set power box in a proper position for easy operation. If power box is placed in public area, it should have settings to prevent non-professional wrong operation. Separate neutral wire and grounding wire and ground resistance value should be no more than 4Ω.

Install permanent lighting device in equipment range and ground illumination value is no less than 200lx. If MR is placed in public area, it is allowed to use public light for illumination.

Please contact with technical department if you choose manual door.

对重侧置自动参数 Automatic parameters of side counterweight

额定载重 Load capacity	额定速度 Rated speed	准载人数 Person	井道尺寸 shaft size 宽C × 深D Width x depth	轿厢尺寸 Car size 宽A × 深B × 高CH Width x depth x height	开门宽度JJ Door opening width	额定电压 Rated voltage	最大提升高度 Max traveling height
Kg	m/s	人	mm	mm	mm	V	m
240	0.4	3	1400 × 1650	750 × 1200 × 2200	600	220	12
320		4	1550 × 1650	900 × 1200 × 2200	700		
400		5	1650 × 1650	1000 × 1200 × 2200	800		

对重侧置手动参数 Manual parameters of side counterweight

额定载重 Load capacity	额定速度 Rated speed	准载人数 Person	井道尺寸 shaft size 宽C × 深D Width x depth	轿厢尺寸 Car size 宽A × 深B × 高CH Width x depth x height	开门宽度JJ Door opening width	额定电压 Rated voltage	最大提升高度 Max traveling height
Kg	m/s	人	mm	mm	mm	V	m
240	0.3	3	1400 × 1550	750 × 1200 × 2200	600	220	12
320		4	1550 × 1550	900 × 1200 × 2200	700		
400		5	1650 × 1550	1000 × 1200 × 2200	800		

# Steel wire rope driving

## (Rear CWT)

别墅电梯土建  
钢丝绳牵引对重后置系列

井道立面图  
Shaft Vertical Section

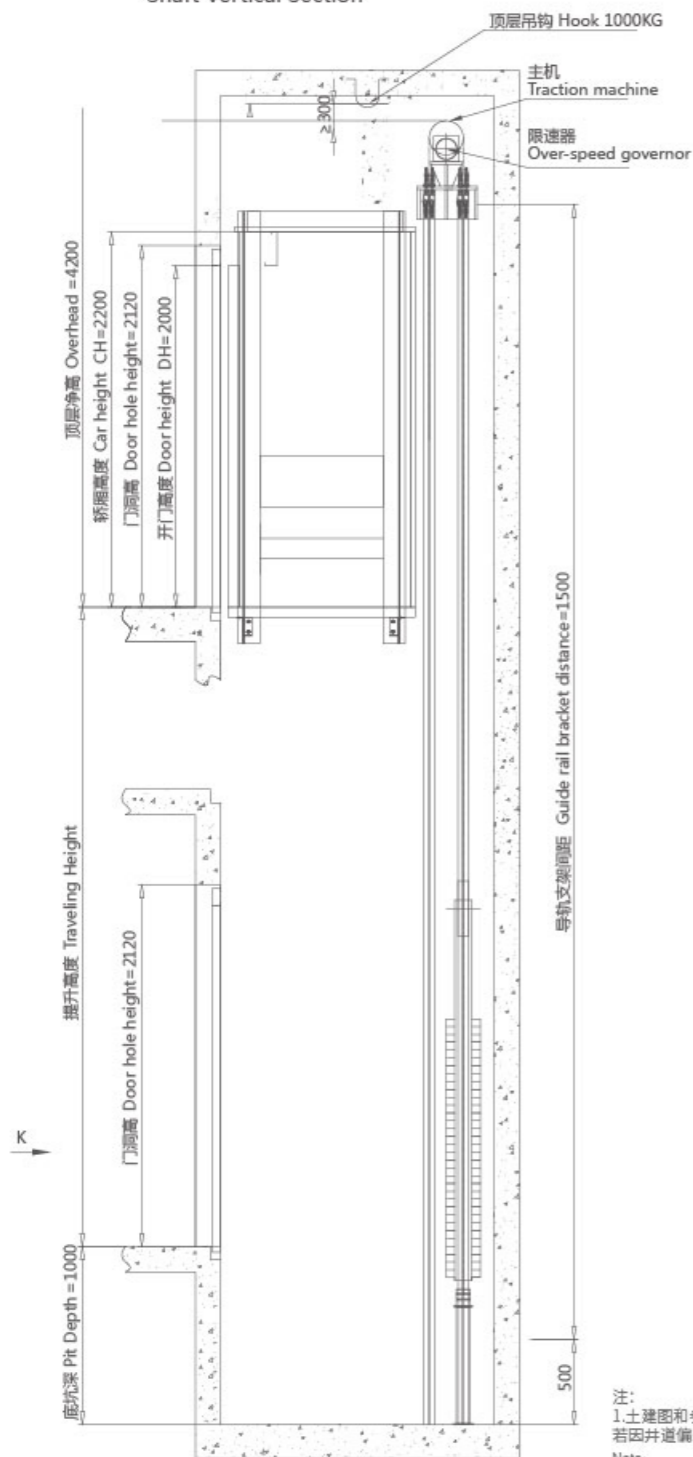

电梯平面布置图方案图  
Elevator plan

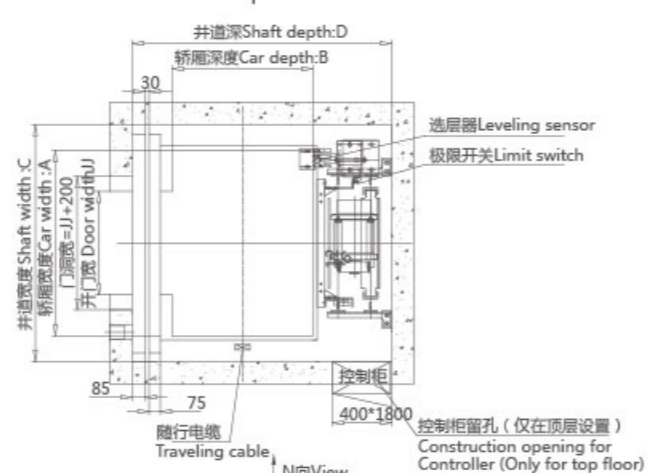

K向厅门正面图  
Landing door plan

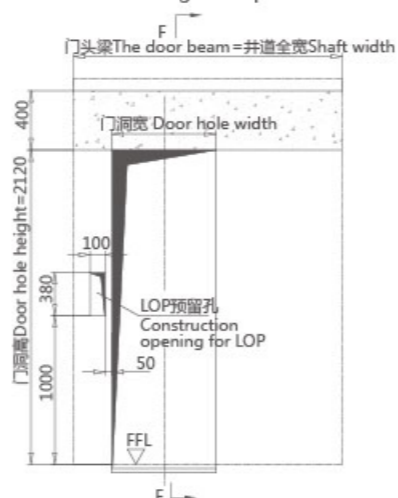

注:  
1. 土建图和参数表仅供参考, 如有疑问, 请咨询技术部。2. 请确保井道垂直度, 让电梯顺利安装, 若因井道偏差导致电梯无法安装的, 需用户自行解决!  
Note:  
1. Construction parameter drawings and tables are for sales reference only. Please consult the company's technical department if you have any question.  
2. Please make sure the shaft is vertical so that the elevator can be installed smoothly. If elevator can't be installed because of shaft deviation, user shall settle it by himself.

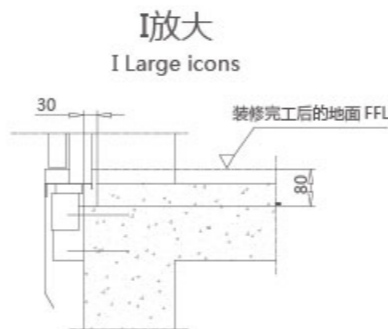

剖面  
Section F-F

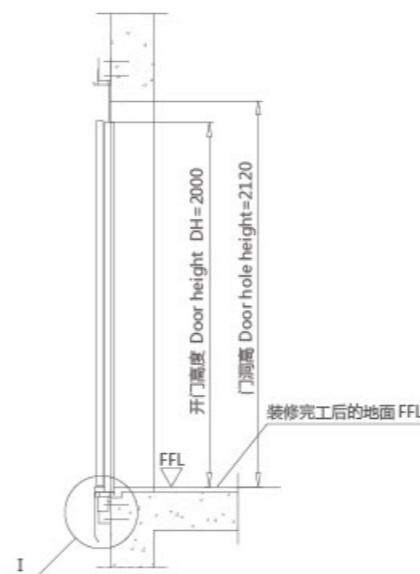

### 业主和土建承包商须注意事项 User and construction contractor should finish the following work

井道应为电梯专用, 不得装设与电梯无关的设备、电缆等。井道内允许装设采暖设备, 但不能用蒸汽和高压水加热, 采暖设备的控制与调节装置应装在井道外面。

电源需有适配的线, 电压220V, 电压波动应在±7%范围内, 其独立的接地装置, 其电阻不得大于4Ω。

井道净尺寸是用铅垂线测定的最小净空间尺寸, 井道高度允许偏差值为0到+25mm。砖混结构井道要求在导轨支架安装处设置300mm高的混凝土圈梁并在每层厅门洞设与井道同宽的混凝土梁, 见厅门正面图。

底坑地面应能够承受不小于规定的负荷; 底坑表面应光滑平整且不得漏水。

机械设备区间工作环境允许温度0°C到+40°C, 相对湿度不大于85%。

控制柜前至少提供宽度不小于0.7m, 深度不小于0.5m的工作区域。通往控制柜的通道应通畅, 且宽度不小于0.8m, 高度不小于1.8m。

最小层楼间距为2600mm, 当相邻层楼间距大于11m时, 应设置井道安全门, 安全门的尺寸不小于350mm宽、1800mm高, 不得向井道内开启。

控制柜旁应能设置电源箱, 电源箱应为电梯专用, 电源箱的位置须合适、应易于专业人员操作。当电源箱处于公共用途的场地时, 应有防止非专业人员误操作的设置。零线和接地线应始终分开, 接地电阻不大于4Ω。

机器设备区内应设置永久照明, 地面的照度不小于200lx; 当机器设备区处于公共用途的场地时, 允许利用公共照明采光。

选手动门时请与本公司技术部联系。

The shaft is specialized for elevator. Do not install other irrelevant equipments and power. It is allowed to install heating equipment in shaft, but steam and high pressure water heating is forbidden. Controller and adjust device for heating equipment should be installed outside shaft.

The fluctuation of the power supply voltage with respect to voltage (220V) should be within the range of +7%. For independent grounding device, its resistance value should be no more than 4Ω.

Shaft size is minimal net size measured by plumb line and vertical deviation 0~+25mm. If shaft is frame structure, install concrete ring beam (height: 300mm) at guide rail bracket install position and concrete beam (width: same as shaft width) at each landing door reserved holes. Please refer to landing door plan.

Strength of shaft wall and pit should bear the force no less than required value. Pit surface should be smooth, flat and with out leaking.

Temperature in equipment range should remain 0-40 deg, relative humidity <= 85%.

In front of controller, there should be a work area (width ≥ 0.7m, depth ≥ 0.5m). Passage to controller should be unobstructed, with width no less than 0.8m, and height no less than 1.8m.

The Minimum floor sill distance is 2600mm. If distance between two floor is more than 11 m, there should be a safety door. Door size should be no less than 350mm × 1800mm. Door can't come into shaft.

Install power box beside control cabinet and power box should be specialized for elevator. Set power box in a proper position for easy operation. If power box is placed in public area, it should have settings to prevent non-professional wrong operation. Separate neutral wire and grounding wire and ground resistance value should be no more than 4Ω.

Install permanent lighting device in equipment range and ground illumination value is no less than 200lx. If MR is placed in public area, it is allowed to use public light for illumination.

Please contact with technical department if you choose manual door.

对重后置自动参数 Automatic parameters of rear counterweight

额定载重 Load capacity	额定速度 Rated speed	准载人数 Person	井道尺寸 shaft size		轿厢尺寸 Car size		开门宽度J Door opening width	额定电压 Rated voltage	最大提升高度 Max traveling height
			宽C×深D Width x depth	mm	宽A×深B×高CH Width x depth x height	mm			
Kg	m/s	人		mm			mm	V	m
240	0.4	3	1600 × 1500		1250 × 650 × 2200		700	220	12
320		4	1600 × 1600		1250 × 800 × 2200		700		
400		5	1600 × 1750		1250 × 950 × 2200		700		

对重后置手动参数 Manual parameters of rear counterweight

额定载重 Load capacity	额定速度 Rated speed	准载人数 Person	井道尺寸 shaft size		轿厢尺寸 Car size		开门宽度J Door opening width	额定电压 Rated voltage	最大提升高度 Max traveling height
			宽C×深D Width x depth	mm	宽A×深B×高CH Width x depth x height	mm			
Kg	m/s	人		mm			mm	V	m
240	0.3	3	1500 × 1400		1250 × 650 × 2200		800	220	12
320		4	1500 × 1550		1250 × 800 × 2200		800		
400		5	1500 × 1700		1250 × 950 × 2200		800		

# 别墅电梯土建 钢带牵引系列

# Steel belt driving

## 业主和土建承包商须注意事项 User and construction contractor should finish the following work

井道应为电梯专用，不得装设与电梯无关的设备、电缆等。井道内允许装设采暖设备，但不能用蒸汽和高压水加热，采暖设备的控制与调节装置应装在井道外面。电源需有适配的线，电压220V,电压波动应在±7%范围内，其独立的接地装置，其电阻不得大于4Ω。

井道净尺寸是用铅垂线测定的最小净空间尺寸，井道高度允许偏差值为0到+25mm。砖混结构井道要求在导轨支架安装处设置300mm高的混凝土圈梁并在每层厅门门洞设与井道同宽的混凝土梁，见厅门正面图。

底坑地面应能够承受不小于规定的负荷；底坑表面应光滑平整且不得漏水。

机械设备区工作环境允许温度0°C到+40°C，相对湿度不大于85%。

控制柜前至少提供宽度不小于0.7m，深度不小于0.5m的工作区域。通往控制柜的通道应通畅，且宽度不小于0.8m，高度不小于1.8m。

最小层楼间距为2600mm，当相邻层楼间距大于11m时，应设置井道安全门，安全门的尺寸不小于350mm宽、1800mm高，不得向井道内开启。

控制柜旁应能设置电源箱，电源箱应为电梯专用，电源箱的位置须合适、易于专业人员操作。当电源箱处于公共用途的场地时，应有防止非专业人员误操作的设置。零线和接地线应始终分开，接地电阻不大于4Ω。

机器设备区内应设置永久照明，地面的照度不小于200lx；当机器设备区处于公共用途的场地时，允许利用公共照明采光。

选手动门时请与本公司技术部联系。

The shaft is specialized for elevator. Do not install other irrelevant equipments and power. It is allowed to install heating equipment in shaft, but steam and high pressure water heating is forbidden. Controller and adjust device for heating equipment should be installed outside shaft.

The fluctuation of the power supply voltage with respect to voltage (220V) should be within the range of +7%. For independent grounding device, its resistance value should be no more than 4Ω.

Shaft size is minimal net size measured by plumb line and vertical deviation 0~+25mm. If shaft is frame structure, install concrete ring beam (height: 300mm) at guide rail bracket install position and concrete beam (width: same as shaft width) at each landing door reserved holes. Please refer to landing door plan.

Strength of shaft wall and pit should bear the force no less than required value. Pit surface should be smooth, flat and with out leaking.

Temperature in equipment range should remain 0-40 deg, relative humidity ≤ 85%.

In front of controller, there should be a work area (width≥0.7m, depth≥0.5m). Passage to controller should be unobstructed, with width no less than 0.8m, and height no less than 1.8m.

The Minimum floor sill distance is 2600mm. If distance between two floor is more than 11 m, there should be a safety door. Door size should be no less than 350mm × 1800mm. Door can't come into shaft.

Install power box beside control cabinet and power box should be specialized for elevator. Set power box in a proper position for easy operation. If power box is placed in public area, it should have settings to prevent non-professional wrong operation. Separate neutral wire and grounding wire and ground resistance value should be no more than 4Ω.

Install permanent lighting device in equipment range and ground illumination value is no less than 200lx. If MR is placed in public area, it is allowed to use public light for illumination. Please contact with technical department if you choose manual door.

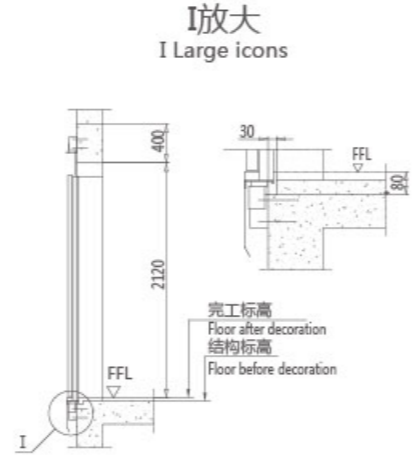
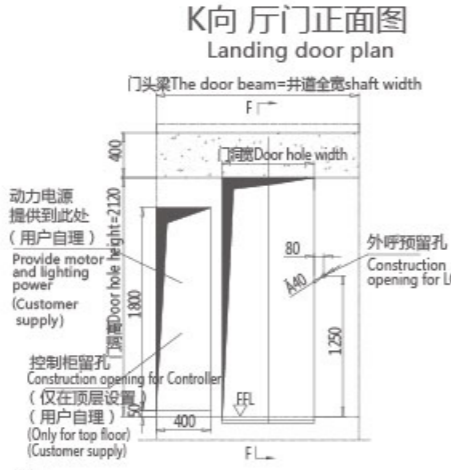
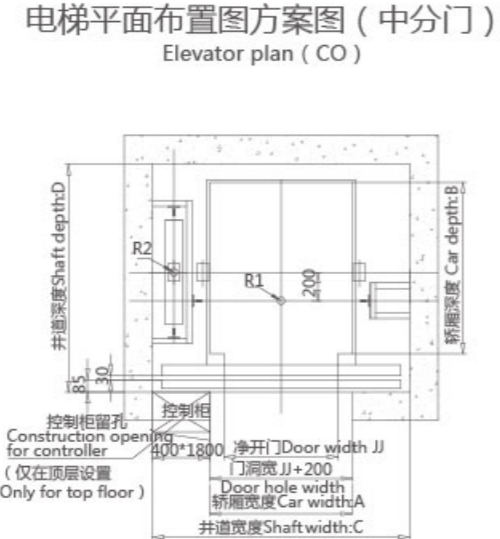
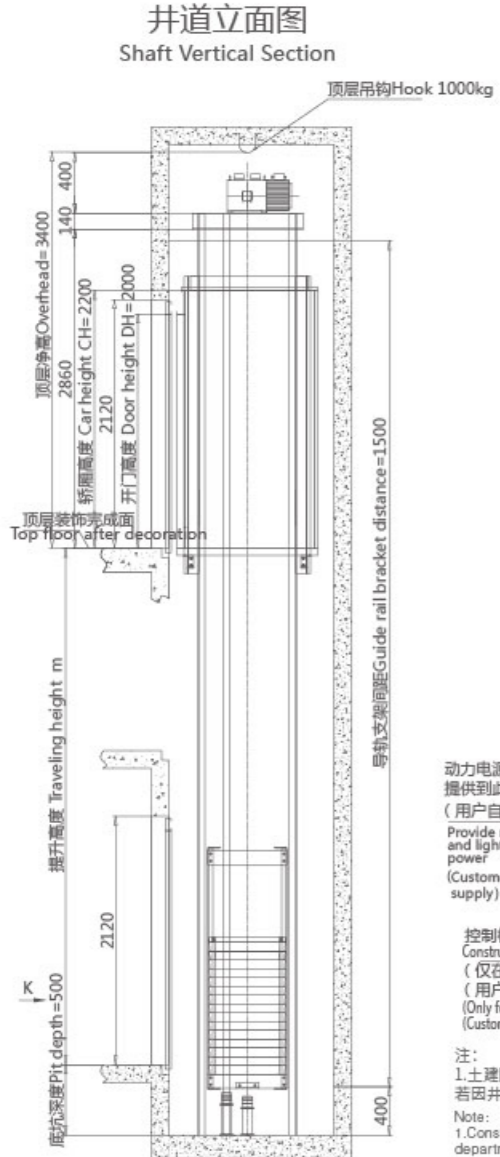

注：  
1. 土建图和参数表仅供销售参考，如有疑问，请咨询技术部。2. 请确保井道垂直度，让电梯顺利安装，若因井道偏差导致电梯无法安装的，需用户自行解决！

Note:  
1. Construction parameter drawings and tables are for sales reference only. Please consult the company's technical department if you have any question.  
2. Please make sure the shaft is vertical so that the elevator can be installed smoothly. If elevator can't be installed because of shaft deviation, user shall settle it by himself.

开门形式 Door opening	额定载重 Load capacity kg	额定速度 Rated speed m/s	准载人数 Person	井道尺寸 shaft size 宽C×深D width×depth mm	轿厢尺寸 Car size 宽A×深B×高CH width×depth×height mm	开门宽度JJ Door opening width mm	钢带数 Number of steel 根 Root	额定电压 Rated voltage V	受重点处R1 Support R1 kg	受重点处R2 Support R2 kg	最大提升高度 Max travelling height m
自动中分 (CO)	400	0.4	5	1800X1600	1000X1200X2200	800	2	220	3200	3200	12
	320		4	1650X1600	900X1200X2200	700					
旁开双折 (SO)	400	0.4	5	1600X1650	1000X1200X2200	800	2	220	3200	3200	12
	320		4	1500X1650	900X1200X2200	700					
手动 (Manua)	400	0.3	5	1650X1450	1000X1200X2200	800	2	220	3200	3200	12
	320		4	1550X1450	900X1200X2200	700					

电梯井道立面图  
Shaft Vertical Section

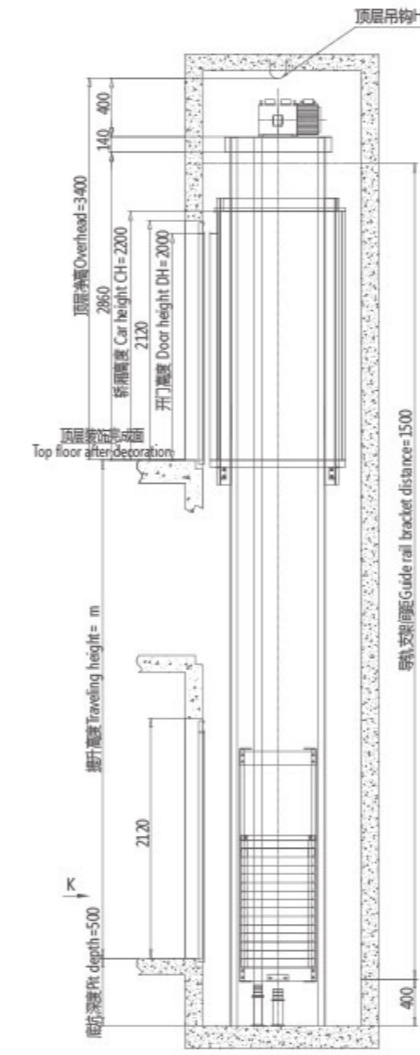

电梯平面布置图方案图(旁开门)  
Elevator plan (SO)

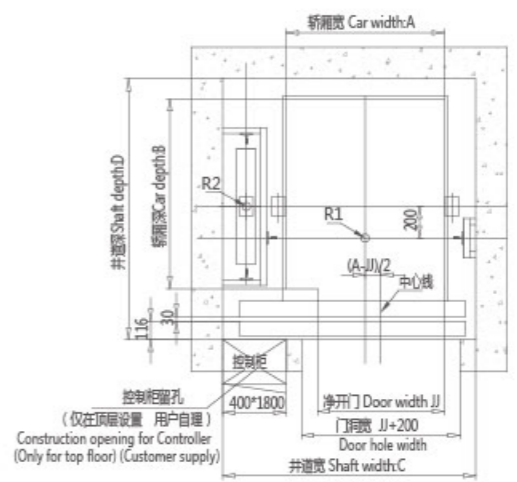

K向厅门正面图  
Landing door plan



I放大  
I Large icons



注：  
1. 土建图和参数表仅供销售参考，如有疑问，请咨询技术部。2. 请确保井道垂直度，让电梯顺利安装，若因井道偏差导致电梯无法安装的，需用户自行解决！

Note:  
1. Construction parameter drawings and tables are for sales reference only. Please consult the company's technical department if you have any question.  
2. Please make sure the shaft is vertical so that the elevator can be installed smoothly. If elevator can't be installed because of shaft deviation, user shall settle it by himself.

# Service and security

服务及安全保障  
之心篇



### 24小时管家服务

林肯别墅电梯，全天24小时随时享受尊崇的主人服务，并通过先进的新兴技术和完善的服务网络，确保客户安全，真正实现贴身的管家服务。

### 24-hour butler service

LINCOLN villa elevator provides users with 24-hour master's service in dignity. Furthermore, its advanced emerging technology and perfect service internet will guarantee security of user, which realizes 24 hours butler services.



### T-call及时通

T-call可以预先设置3个电话号码，分别连接您的家人，办公室直线和维保公司或维保人员，如遇电梯故障无法开门等其他紧急情况，可以通过T-call一键拨通预先设置号码，并根据电话开通情况顺序切换，确保及时得到救援响应和帮助。

### T - call instant messaging

T - call can set three phone numbers in advance respectively connecting to your family, office line and maintenance company or maintenance personnel. In emergency case, such as door open fault, users can call pre-set numbers through T - call and switch in sequence according to connect condition to ensure timely rescue and help.



### T-power源动力

当电梯运行过程中突发停电情况，T-power会迅速启动，迅速给电梯提供第二电源，确保乘客安全离开电梯。

### T - power

In case of sudden power failure in elevator operation, T - power will start quickly to provide second power supply, and passengers can leave elevator safely.



### 从您出发，从心出发

因为您，我们所做的一切才有了意义。林肯电梯始终认为给予客户最佳的服务就是“以人为本，以您为本”，始终聆听客户最深处的需求，最真挚的反馈，事事从心出发。让周到、安心、真诚的服务与您上下随行。

### Start from you and start from heart

It is you that makes all what we have done meaningful. Lincoln elevator always thinks that the best service provided for clients is people-orientation and consumer-orientation. We are always listening to needs and feedback of users. Do everything from heart to guarantee considerate, realizable and sincere service accompany you all the time.



以人为本的服务理念  
People orientated service idea

